

Section view B-B

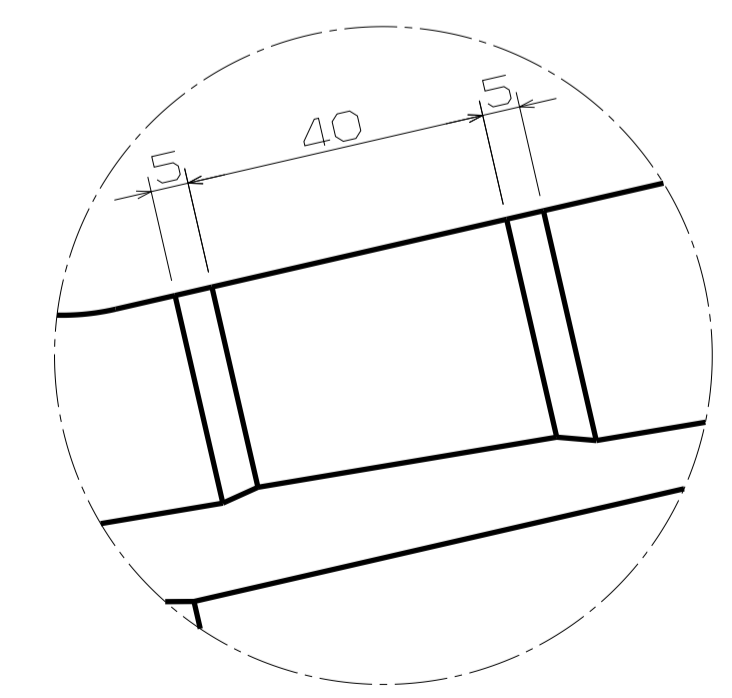

Auxiliary view C-C

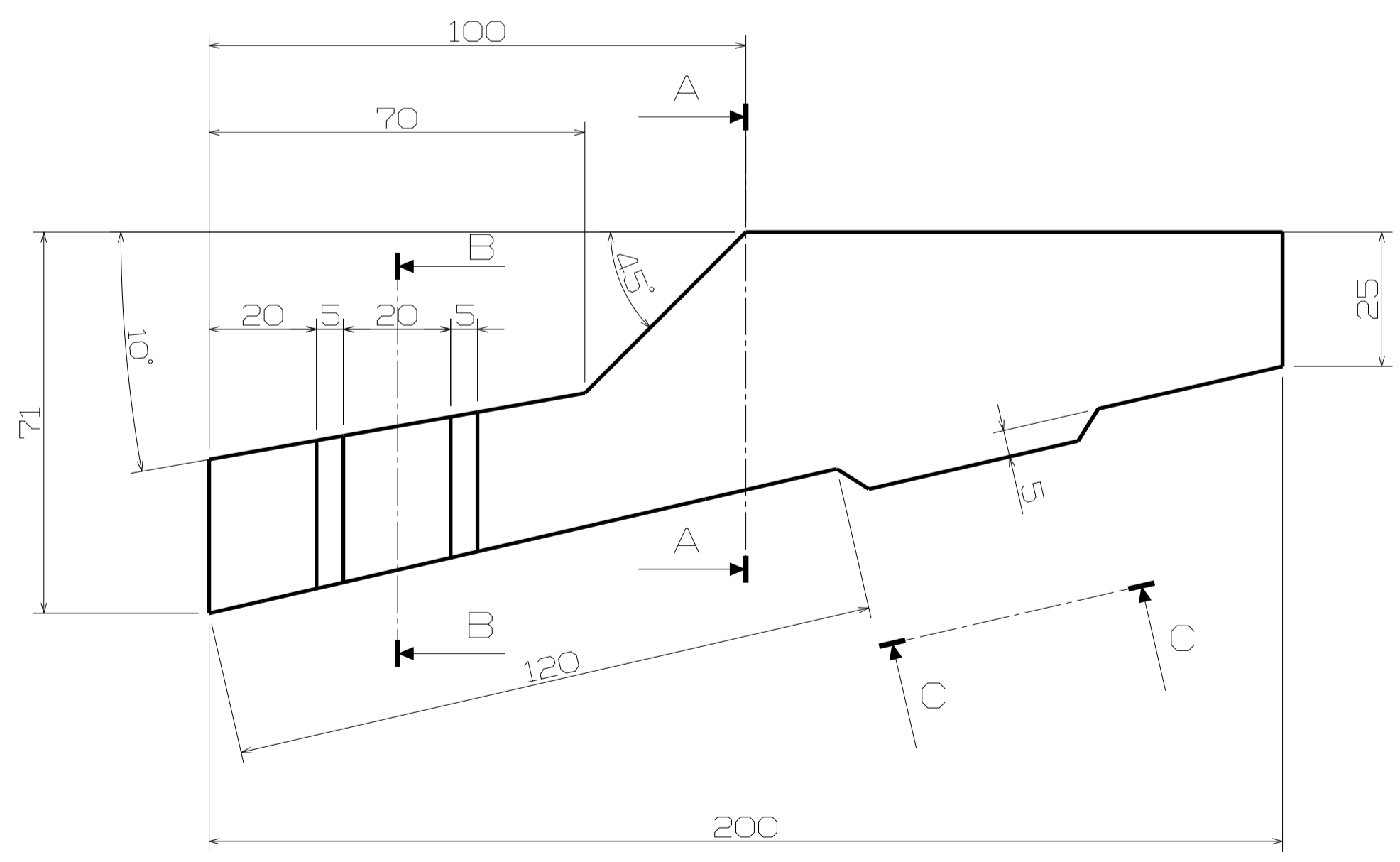
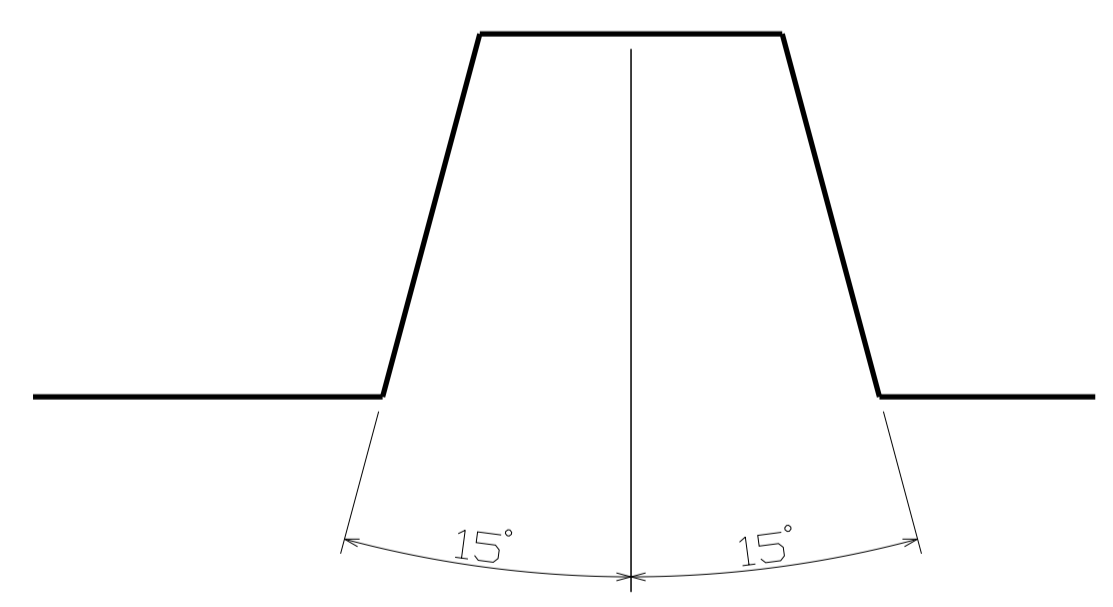

Section cut A-A